

THIS DRAWING IS UNPUBLISHED. RELEASED FOR PUBLICATION, 19 .
 © COPYRIGHT 19 BY AMP INCORPORATED. ALL INTERNATIONAL RIGHTS RESERVED.

LOC	DIST	P	F	ZONE	LTR	DESCRIPTION	DATE	APPD
AF	50				H	REV PER 063A-0076-99	30JUL99	JR/SH

1 CONTINUOUS STRIP ON REELS.

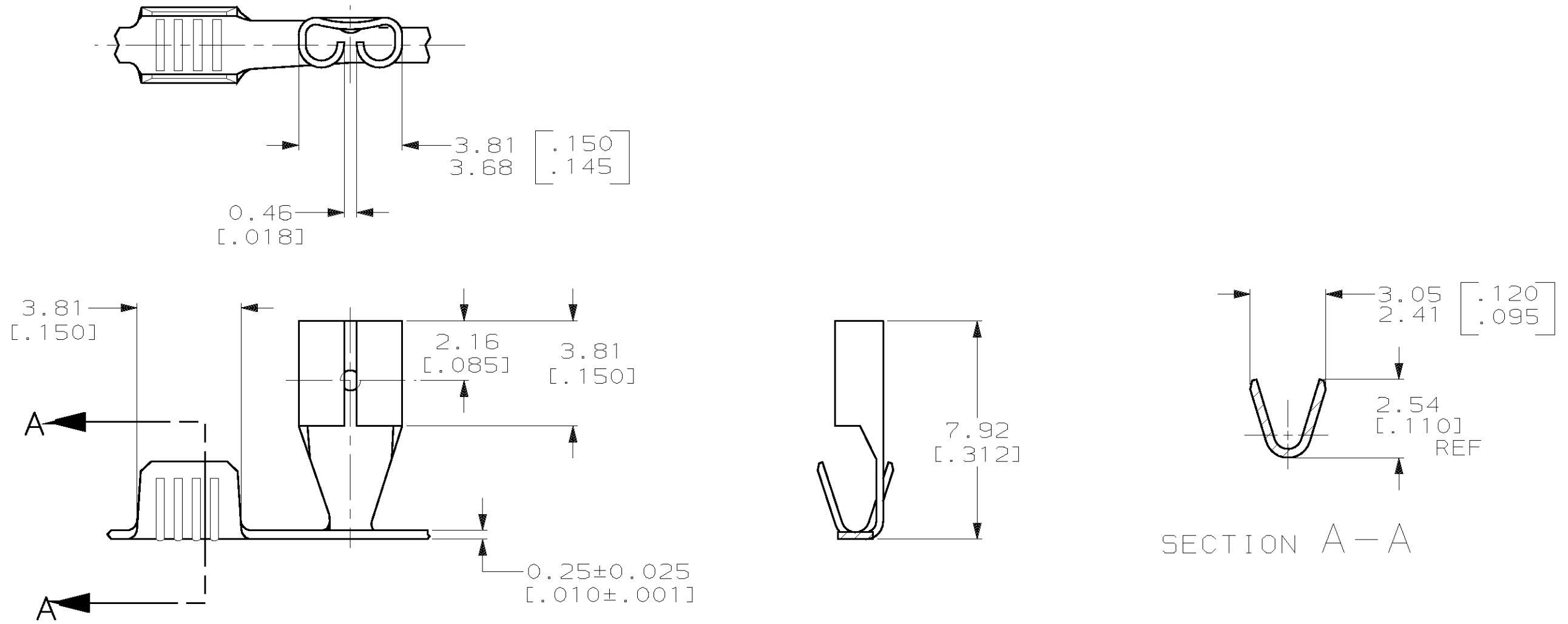

5.59 [.220]		F	1.78 [.070]	1.42 [.056]	16	DO NOT SCALE PRINT. UNLESS SPECIFIED DIMENSIONS IN mm [INCHES] TOLERANCES ON: 2 PLC DEC ± 0.38 [.015] 3 PLC DEC ± - ANGLES ± -	DR 4/18/96 JR RUTH	AMP AMP Incorporated Harrisburg, PA 17105-3608	NAME RECEPTACLE, FASTON, 2.79 [.110] SERIES	
STRIP LENGTH TYPE ±0.38 [.015]		WIDTH	HEIGHT	1.19 [.047]	18		CHK 4/18/96 MS FEHER			
WIRE BARREL CRIMP				1.04 [.041]	20		APPD 4/18/96 P DESANTIS	SIZE B	CAGE CODE 00779	DRAWING NO C-61549
				0.96 [.038]	22		APPD 4/18/96 V KARABCIEVSKY	SCALE 6:1	SHEET 1 OF 1	
						MATERIAL H04 BRASS	PRODUCT SPEC -			
						FINISH PRE-TIN	APPLICATION SPEC 114-2028			
							WEIGHT -			

THIS DRAWING IS A CONTROLLED DOCUMENT FOR AMP INCORPORATED. IT IS SUBJECT TO CHANGE AND THE CONTROLLING ENGINEERING ORGANIZATION SHOULD BE CONTACTED FOR THE LATEST REVISION.